

I.D. ALIGNMENT/ADJUSTMENT OF THE MICROSCOPE

I.D.1. Introduction

Misalignment of the TEM can interfere with its **resolving power** because instabilities in high voltage or lens current produce image movements the extent of which increases with the degree of misalignment. Misalignment of a lens means that the imaging pencil of electrons is not centered around the axis of the lens, but around an axis oriented at an angle to the lens axis. Because of the substantial aberrations of electron lenses, an image of acceptable quality is produced only within a limited paraxial region. Alignment of the imaging lenses causes the optical center of the image to coincide with the physical center of the viewing screen.

Misalignment also produces serious inconveniences in operation such as movement of the field of view during changes in magnification or focusing. The operator wishes to be able to:

- Change magnification without losing the center of the field of view.
- Vary the illumination on the object without the illumination becoming uneven or off-center.
- Focus the image without it moving across the screen.
- Switch from one mode of operation to another without loss of illumination.

Ideally, the optical elements of any microscope must be coaxial. That is, the axes of symmetry of each lens must exactly coincide. Alignment must be affected with respect to the electron gun, and the condenser and imaging lenses. The evaluation of the alignment of the microscope column is simple due to the translational movement of the image associated with a change in the strength of a lens in the case of misalignment.

The procedure of aligning the microscope is based on the observation of movements of the image produced by a lens when the strength of the lens is changed, and on the correction of the alignment of the whole optical system located above the lens in relation to the lens in such a way that the image movement will be minimal. Although the exact method of alignment will vary between different microscopes, the basic principles are usually similar. In most instruments, the center of the objective lens and the center of the viewing screen constitute two points which define the optic axis.

I.D.2. Alignment of TEM Components

a. Electron gun

The **first step** in aligning the microscope column usually involves adjusting the position of the gun and condenser lenses in relation to the objective lens. This alignment involves adjusting the position of the gun relative to the condenser lens and of the gun-condenser lens system relative to the objective lens. Gun alignment centers an image of the emitting filament on the viewing screen. The hole in the Wehnelt is usually small (~1mm) and consequently a small displacement (translation or tilt) of the filament tip will generate a highly asymmetric electrostatic field at the filament tip which will distort the emission, throw the center of the beam off axis and greatly reduce overall illumination intensity (Fig. I.110).

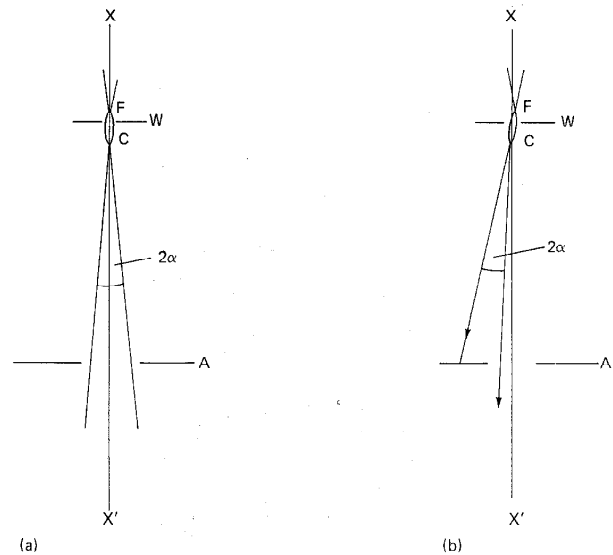

Fig. I.110. The effect of misalignment of the filament F with respect to the Wehnelt cylinder W. (a) Aligned; the beam passes through the anode A and then symmetrically down the axis XX' of the condenser lens. (b) Misaligned; part of the beam is lost on hitting the anode A, reducing the total beam angle  $2\alpha$ . (From Agar, p.124)

**b. Condenser**

Condenser alignment ensures centering of illumination at all levels of condenser current. When the condenser is badly misaligned, the illumination can sweep entirely out of the field of view as the level of current is altered (Fig. I.111, I.112). Although the focused illumination may be centered, the illuminated area will not expand uniformly about the screen unless the condenser lens apertures are also centered (Fig. I.113). Astigmatism in the second condenser lens produces an elongated, asymmetrical spot shape as the beam is defocused. To achieve more uniform spreading of the beam, the condenser lens astigmatism is corrected by means of condenser stigmators.

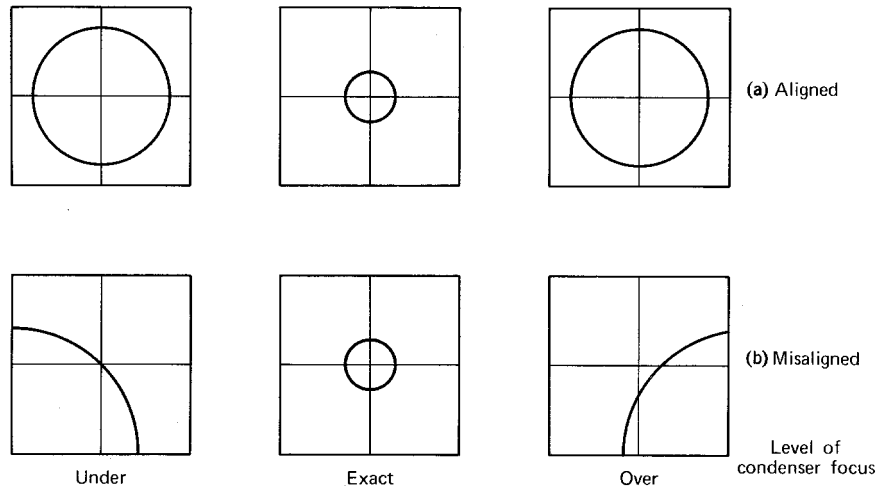

Fig. I.111. Condenser sweep. (From Slayter, p.400)

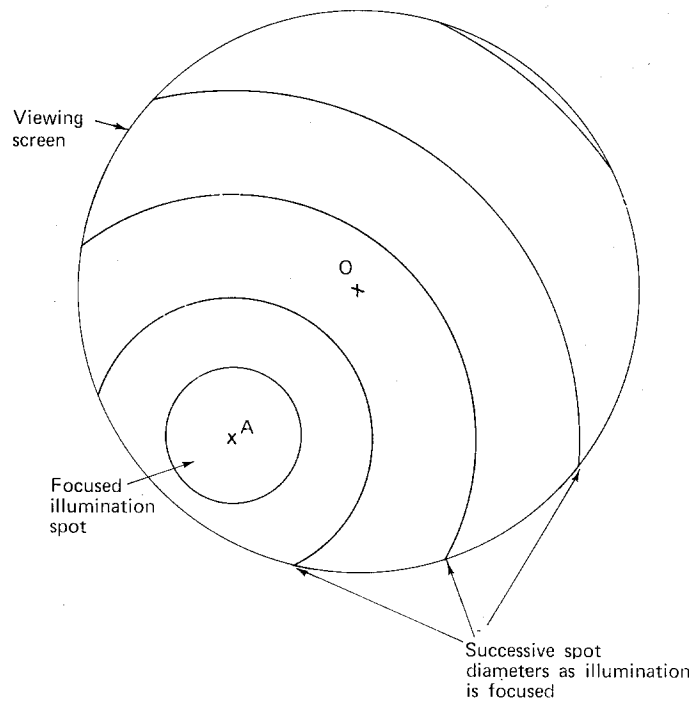

Fig. I.112. The appearance of illumination on the viewing screen with a misaligned condenser. The successive circles represent the limit of the illuminated area as the condenser lens is focused. The center of the focused spot is marked A. The screen center is at O. (From Agar, p.127)

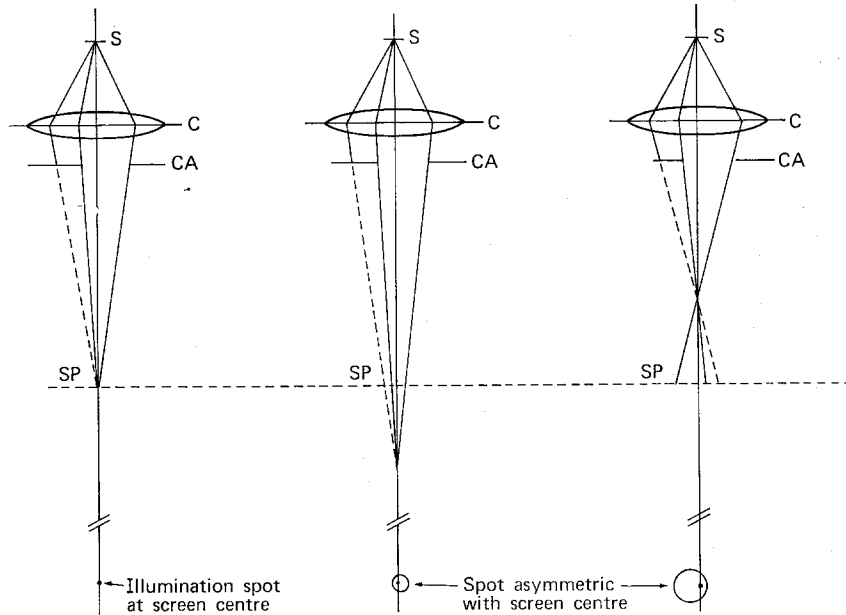

Fig. I.113. The effect of a misaligned condenser aperture CA with change in condenser focus. (a) With the illumination from the source S focused on the specimen plane SP the spot appears symmetrical at the screen center. As the illumination is (b) underfocused and (c) overfocused, the illumination appears asymmetric to the screen center. (From Agar, p.128)

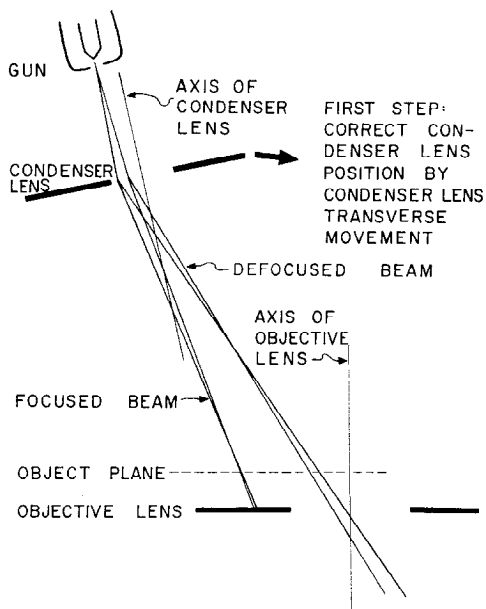

Fig. I.114. Alignment of the electron microscope, step 1. (From Sjostrand, p.315)

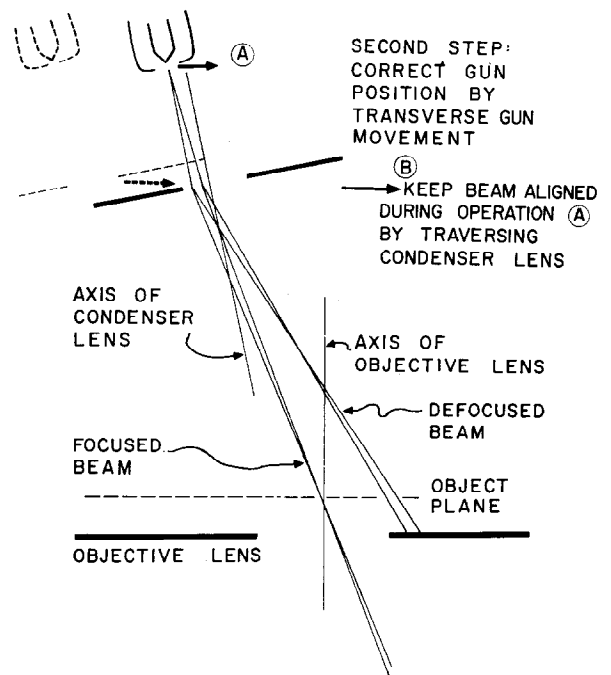

Fig. I.115. Alignment of the electron microscope, step 2. (From Sjostrand, p.316)

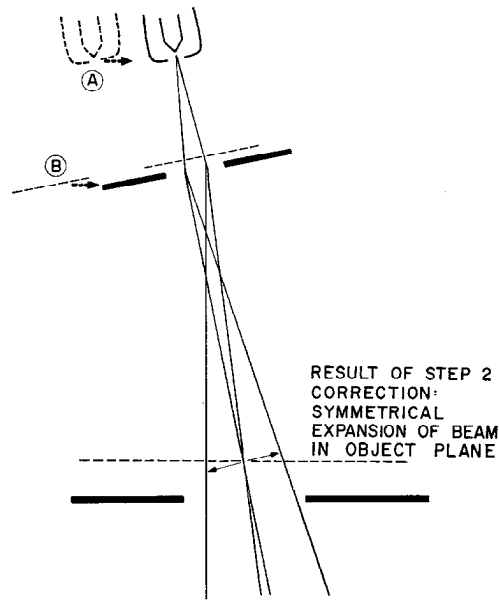

Fig. I.116. Alignment of the electron microscope, result of step 2 correction. (From Sjostrand, p.317)

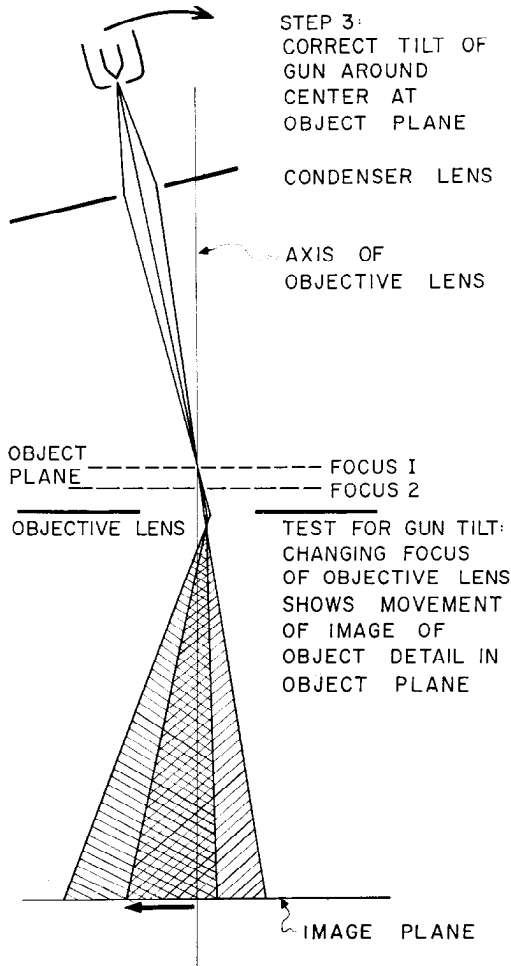

Fig. I.117. Alignment of the electron microscope, step 3. (From Sjostrand, p.318)

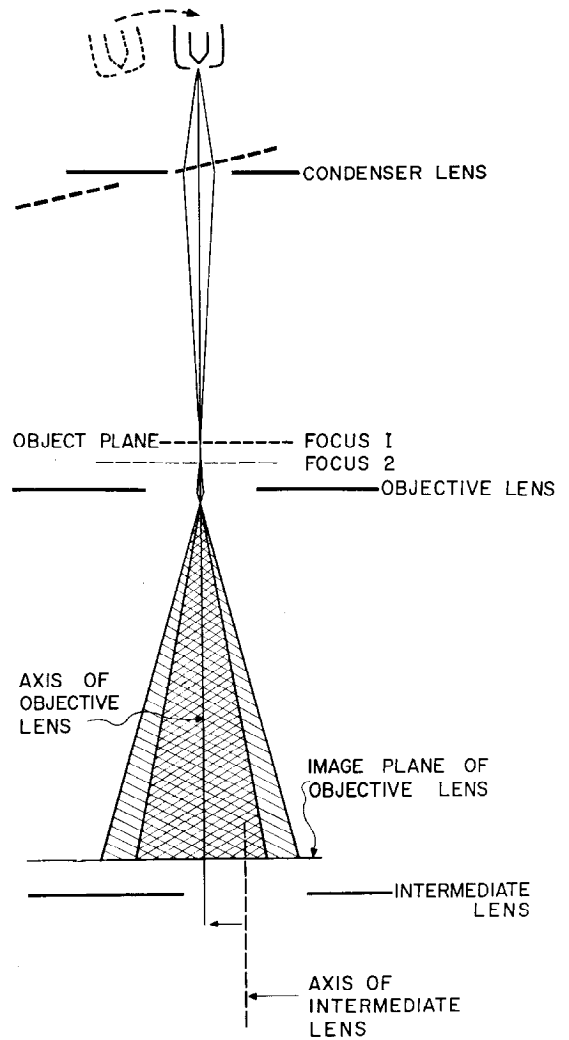

Fig. I.118. Alignment of the electron microscope, result of step 3 correction. (From Sjostrand, p.319)

c. Imaging system

The alignment procedure must result in the axes of all the image forming lenses being in line and on the mechanical axis of the instrument. Once all the imaging lenses are in line, an object point lying on the axis of the objective lens will be imaged at the center of the viewing screen whatever the magnification setting, although the image and object may be rotated with respect to each other.

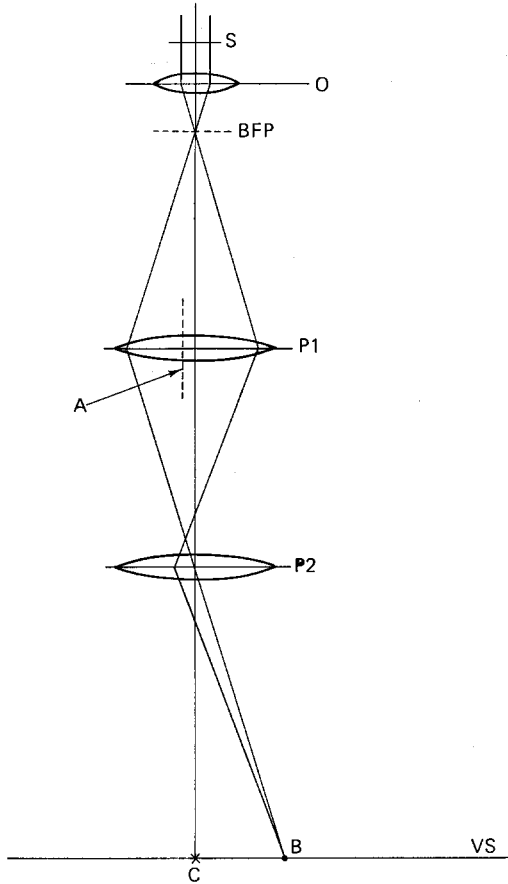

Fig. I.119. Alignment of the intermediate (or first projector lens) P1. The image of the source is formed on the axis of the objective lens O in the back focal plane BFP. If the axis A of P1 is not on the axis of O and P2 (second projector lens), the image of the crossover is formed at B on the viewing screen VS, away from the screen center C. When A is aligned with the instrument axis, B moves to C. (From Agar, p.133)

*Voltage and current centers*

Changes in the accelerating potential result in an expansion or contraction coupled with a rotation of the image around a point in the image plane. Fluctuations in the high voltage results in sharp definition of the image only near an axis or **voltage center**. Image quality is affected least if the voltage center is in the center of the field of view. The farther an image point is from the voltage center the greater will be its movement when the accelerating potential fluctuates (Fig. I.120).

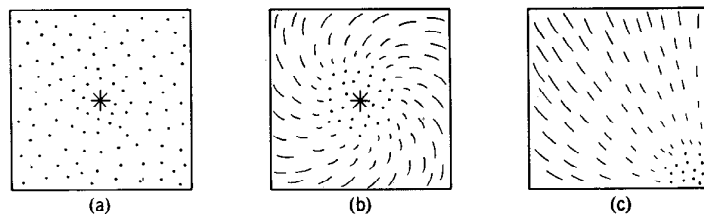

Fig. I.20. Effects of misalignment and high voltage ripple: (a) ideal image; (b) image formed when regulation of high voltage is defective; (c) misaligned image.. (From Slayter, p.401)

\*

Fluctuations of lens current levels likewise cause images of different magnifications to superimpose, also resulting in a composite image which is sharp only at an axis, the **current center**. Ideally the voltage and current centers should coincide, but in practice they do not do so exactly because axial asymmetries are hard to eliminate during manufacture of the lenses. Thus, the microscope has to be aligned with respect to either high-tension or lens current fluctuations. Since, in most microscopes, the voltage fluctuations are greater than the current fluctuations, it is desirable to align the voltage center.

However, most microscopes are not designed to permit small, continuous changes in the accelerating voltage whereas the lens currents can be varied in a continuous fashion.

Lens alignment in older model microscopes such as the Philips EM300, consists of physical translation of the lenses so that either the voltage or current center coincides with the physical microscope axis. In virtually all modern microscopes such as our Philips CM200-FEG and CM300-FEG, alignment is adjusted electronically.

*Illumination tilt*

Although the illumination may already be adjusted laterally to fall onto the object at the objective lens axis, if the axis of illumination is inclined at an angle to the axis of the objective lens, movement of the image will take place with changes in the objective lens current (Figs. I.117 and I.121).

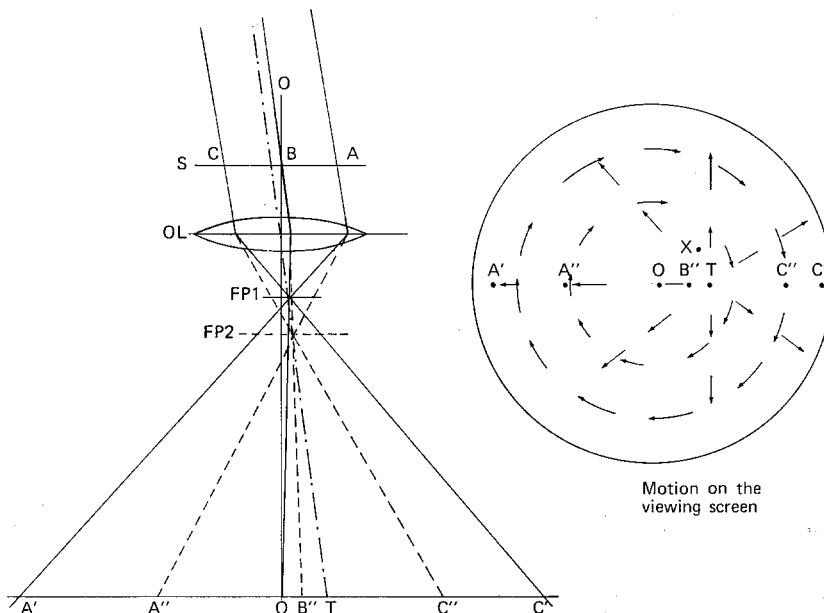

Fig. I.121. The effect of illumination tilted with respect to the objective lens (OL) axis. OO is the objective lens axis, S is the specimen, T is the position of the illumination tilt axis at the final screen. Change of objective lens strength, moves the back focal plane from FP1 to FP2. On the viewing screen point A' moves to A'', C' to C'' and O to B''. The expansion of the picture (due to magnification change as the lens strength alters) is centered at T. The rotation center is at O. The apparent center of rotation due to combination of these motions is at X. (From Agar, p.134)

*Objective aperture*

The objective aperture is generally centered by viewing the plane of the aperture in diffraction mode in the presence of a scattering object such as a carbon film (Fig. I.89). A bright spot is seen at the center of the back focal plane (from the "unscattered" electrons) while the edge of the objective aperture is clearly visible, due to electrons scattered from the object which hit it. The aperture is centered about the bright central spot using fine x-y translation adjustment controls.

**I.D.3. Disturbances to Microscope Performance**

**a. Contamination**

Astigmatism as well as drift and decreased contrast are caused by contamination of the column, apertures and specimen with material of low electric conductivity, which becomes charged when hit by scattered electrons and thus introduces an electrostatic field the strength of which can fluctuate due to charging and discharging of the contaminating material. The variation in the field strength associated with these changes in charge can make the image move back and forth in a certain direction. Contamination of the column (usually the specimen holder) causes the image to move when the illumination beam is moved.

With time, small details in specimen structures become obscured by the layer of contamination

and the contrast of the specimen as a whole is reduced by the deposition of a uniform layer of contamination. The resulting thickening of the specimen causes increased chromatic aberration effects, thus limiting resolution. Fortunately, contamination is virtually eliminated when an **anti-contaminator** is used to preferentially condense potential contaminants on its surface rather than on the specimen.

### b. Image drift and mechanical instabilities

Exposure times of the order of 1-4 seconds are generally required for the photographic recording of electron images. Thus, movements of the specimen through only a few tenths of a nm per second can limit resolution. Movements may result from instabilities of the specimen holder and stage assembly or of the specimen itself.

#### *Thermal drift*

Thermal drift of the specimen due to expansion or shrinkage of the supporting film or asymmetric expansion of the specimen grid or grid holder when exposed to the beam is a common source of blurred images. Thermal drift may be due to supporting films which are too thin, the presence of dirt particles on the film within the illuminated area, or an improper contact between the supporting film and the grid. One way to minimize thermal drift is to reduce the specimen area which is exposed to the beam, thereby reducing the heating of the specimen. Intact support films (carbon) of high stability help minimize specimen problems. Also, copper grids are good conductors of heat that help minimize thermal movements of the specimen.

Minute drift may go undetected during viewing of the screen but will appear in the photographic plate as a unidirectional blurring of the image details. The amount of drift can be measured by making a series of multiple exposures over a time span of a few minutes (Fig. I.122). Drift can be distinguished from astigmatism by comparing pictures taken under different conditions of focusing. Astigmatism tends to be reduced if the image is defocused, but a fuzziness caused by drift is not improved by defocusing.

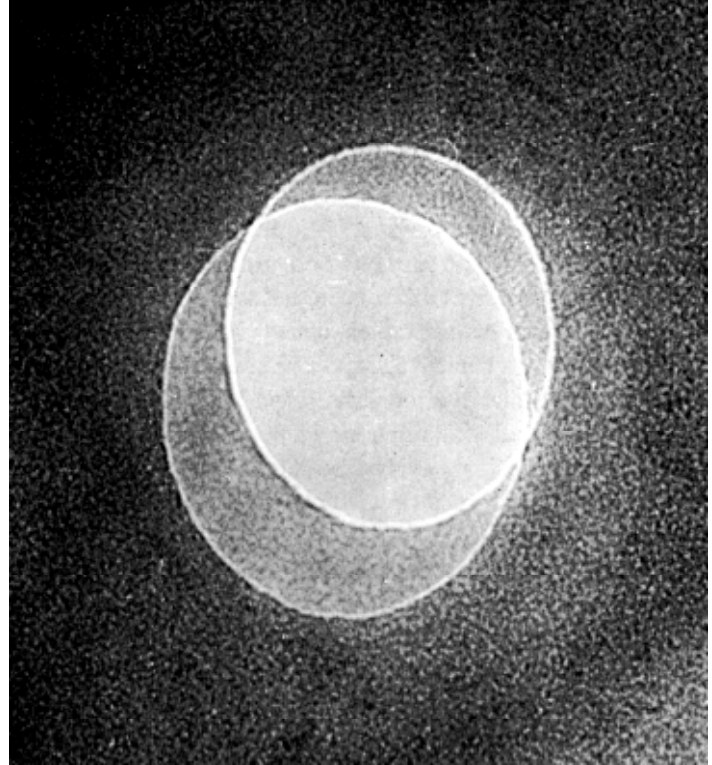

Fig. I.122. Double exposed micrograph of a hole in a carbon film showing drift of the specimen between exposures, and also the deposit of a layer of contamination, showing up as a reduction in hole diameter. Magnification ~300,000X. (From Agar, p.154)

#### *Mechanical vibration*

The site of the laboratory may be subject to ground vibrations (earthquakes, outside traffic, slamming doors, etc.) causing a directional blur in images in the direction of the vibration. Appropriate location and mounting of the instrument are essential to eliminate vibrations of the microscope column. Vibrations from the mechanical pump also must be isolated from the microscope.

### c. Electrical and magnetic instabilities

Lens currents vary at the level of about one part in  $10^5$ . These induce corresponding fluctuations in lens strength (focal length). Since these fluctuations are rapid, images of different magnifications and rotations are superimposed. The use of superconducting lenses, where a single pulse of voltage causes a current to flow for an indefinite time, reduces such current fluctuations.

The level of current produced in this way is free of any variation in the level of voltage supply.

EM columns are constructed from materials designed to shield the electron beam from external fields, nevertheless, strong stray fields can cause marked deterioration of image quality. The microscope must be located away from power lines, magnets (e.g. NMR equipment), large electrical equipment, etc. The effect of an ambient field will be uniform across the field of view, and, in this respect, will be similar in appearance to the effect of mechanical vibration. If the source of trouble is a field, the blur will be reduced at higher voltages, whereas if the blur results from mechanical vibrations, the magnitude will remain unchanged at different voltages. Even with non-ferromagnetic grids such as copper, images of regions of the specimen which are close to the grid bar supports should not be recorded.

#### d. Image astigmatism

##### *Resolving power*

In the absence of other aberrations, resolving power,  $d$ , is limited by objective lens asymmetry approximately to the extent given by:

$$d = \sqrt{\Delta f \cdot \lambda}$$

where  $\Delta f$  = maximum difference in the focal length of the asymmetric lens

$\lambda$  = electron wavelength.

No true, in-focus image can be formed by an asymmetric lens. The minimum change in the objective lens current which is needed for moving the image from complete underfocusing to complete overfocusing can be used as a rough quantitative measure of the degree of astigmatism, since it is a measure for the distance between the two line foci. For a more precise evaluation of the astigmatism, the width of the Fresnel fringes in overfocused pictures can be measured. The fringe width is measured as the distance from the center of the black line to the center of the white line. With the edge in focus in one direction, the fringe width in the overfocused direction gives a measure of the astigmatism.

##### *Correcting astigmatism*

The objective stigmator is used to compensate for the astigmatism in the image. The stigmator allows a small field (electrostatic or electromagnetic) to be added to the asymmetric field in such a way as to compensate for the asymmetry, thus producing a symmetrical field.

There are two common protocols for correcting astigmatism:

- With a holey-carbon film, obtain a slightly over-focused image of a small hole at 50,000-100,000X and adjust the stigmators to make the over-focus fringe symmetrical with respect to the edge of the hole (Fig. I.123). The fringe should move into and out of the edge symmetrically when the objective lens focal position is alternated on either side of the in-focus setting.
- Adjust the stigmator to reduce the phase contrast in the image (usually the background carbon film viewed at high magnification) by as much as possible. When the image is astigmatic, there is no sharp point where the focus of the objective lens gives rise to a sharp drop in phase contrast near the "in-focus" setting. After focusing the image as accurately as possible, the stigmator controls are used essentially as fine focus controls to minimize contrast. When the image is nearly perfectly stigmatized and the objective lens is alternately adjusted between under- and over-focus settings, contrast rapidly increases on either side of the near-focus setting (Figs. I.108 and I.124). This method is very useful because it can be used on any area of the specimen (usually the phase granularity of the support film), without having to search for a suitable small hole around which Fresnel fringes can be observed.



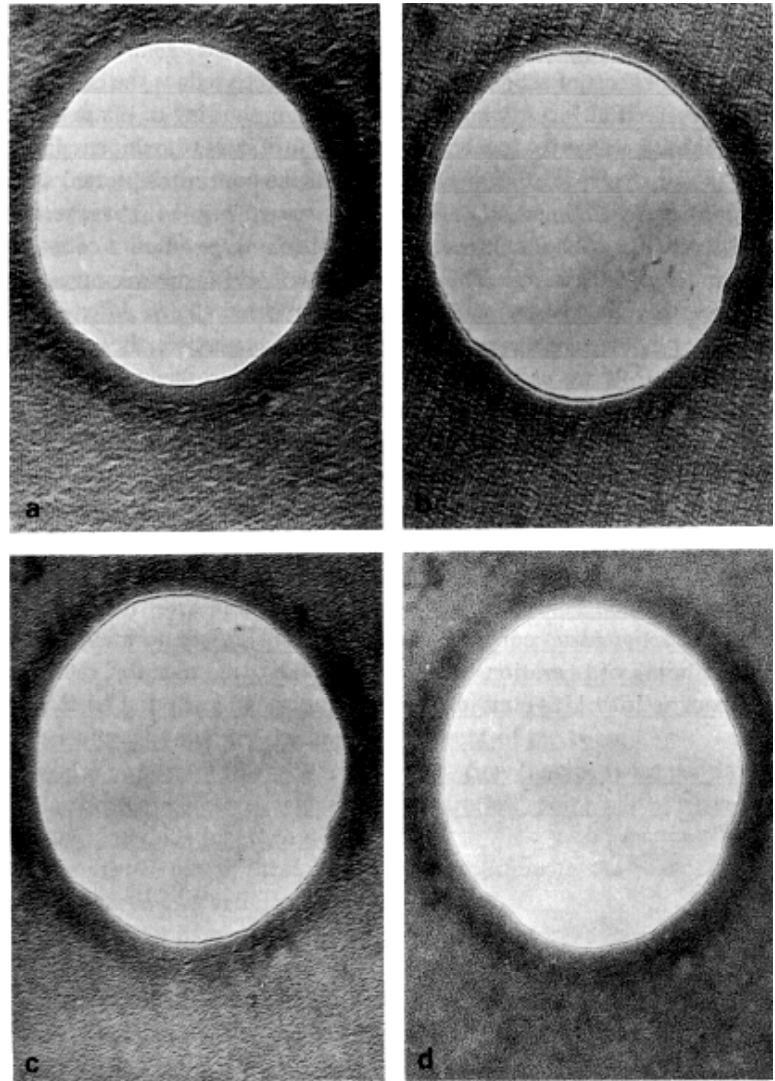

Fig. I.123. The correction of objective lens astigmatism. (a) A Fresnel fringe showing asymmetry in width due to astigmatism in the objective lens. (b) Astigmatism corrector switched on full strength, in an arbitrary direction. Note increased astigmatism. (c) Corrector oriented to oppose the astigmatism of the objective lens. Note that a short length of under-focus fringe now occupies the place of the over-focused fringe in (a). (d) Corrector strength reduced to obtain a uniform fringe. Magnification ~500,000X. Fringe width 0.4nm. (From Agar, p.139)

Compensation of asymmetry becomes a trial and error process, requiring considerable experience before one truly masters the skills involved. In principle, asymmetry may be corrected to any desired level, but in practice it is very often the factor which limits the resolution achieved by electron lenses.

**e. Focal drift**

When small focus changes are observed in the image, it is far more likely to be due to dirt in the gun than a fault in the electrical supplies. Any dirt, no matter how minute, will lead to micro-discharges in the gun and hence a change in the accelerating voltage which causes a change of focus. Components that need frequent cleaning (usually when the filament is changed) are the filament assembly, the anode, and gun body.

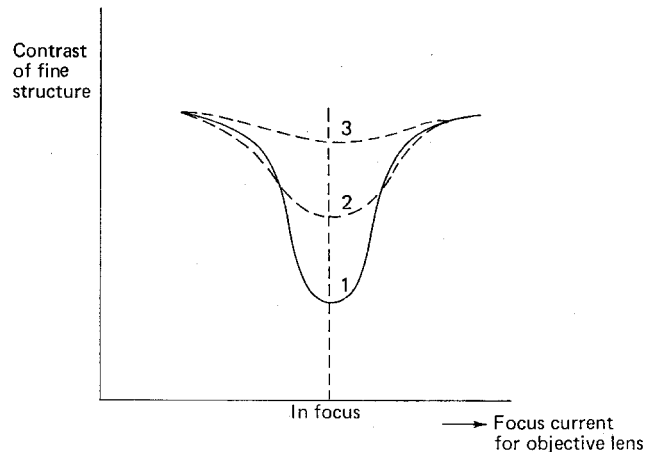

Fig. I.124. The effect of objective lens astigmatism on the image contrast at focus. Curve (1) no residual astigmatism - sharp contrast dip. Curve (2) slight astigmatism - smaller contrast dip. Curve (3) considerable astigmatism - imperceptible contrast change. (From Agar, p.140)